

FREEZER | Chestfreezers

CAN FREEZER ► GLASS TOP



HN 80

CUSTOMIZATION AVAILABLE
PERSONALIZZAZIONE DISPONIBILE

60 mm | C1 -18°C | ENERGY CLASS D | A +16°C/80RH +30°C/55RH | GAS R600a

DETAILS

Tempered glass top | Spacer included | Wheels for easy positioning

GENERAL FEATURES

- 80 Lt. Cans freezer with glass top
- External in black coated plate, grey painted steel internally
- Static Cooling
- Manual Defrost
- Foaming Agent Cyclopentane (60mm per side)
- Handle along door profile
- Single tempered safety glass (Low-E)
- Spacer included
- N.4 Castor (N.1 in the front with brake)
- Energy efficiency class: D

TECHNICAL SPECIFICATIONS

Capacity	77 L
Temperature	C1 (-18°C)
Consumption	1.26 kWh/24h
Rated Power	100 W
Noise level	36 dB(A)
Net Weight	29 Kg
Gross Weight	34 Kg
External Dimensions (WxDxH mm)	569x569x849
Internal Dimensions (WxDxH mm)	458x458x460
Packaging dimensions (WxDxH mm)	585x585x880
Loading quantities 20'/40'/40'HQ	80/160/240

PRODUCT DIMENSIONS

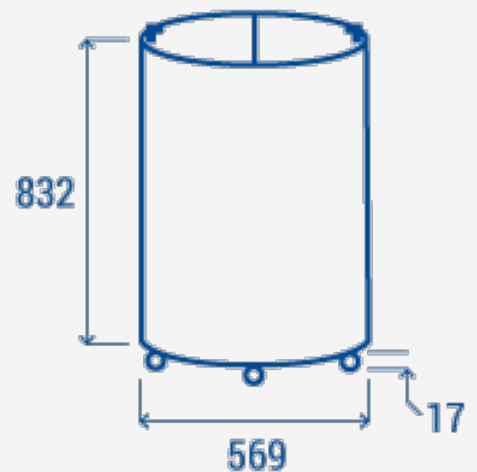

CERTIFICATION

CE RoHS

